

# Solenoid valve(3/2 way)

## 3V2M Series



### Symbol



### Product feature

1. Direct acting type and normally closed mode, flexible in direction change.
2. Normally closed and normally open types are optional.
3. Structure in coaxial blanking mode: leakage proof and large air flow.
4. No need to add oil for lubrication.
5. Affiliated manual devices are equipped to facilitate installation and debugging.
6. Valve needs to be used with the sub-base and allows various connection combinations to save space.
7. It is easy to examine when there are faults owing to the unified air intake and exhaust and unified wiring.
8. Flexible combination and strong expansion capability can make any combination or expansion of the numbers of direction control valves that are connected.
9. Can adjust the installation direction of special sub-base seal for NO or NC functions.

### Specification

Model	3V2M
Fluid	Air(to be filtered by 40 μm filter element)
Acting	Direct acting
Port size [Note1]	1/8"
Valve type	3 port 2 position
Orifice size	1.7mm <sup>2</sup> (Cv=0.1)
Exhaust type	Centralized exhaust, Separated exhaust
Operating pressure	0~0.8MPa(0~114psi)
Proof pressure	1.2MPa(175psi)
Temperature	-20~70°C
Material of body	Aluminum alloy

[Note1] PT thread, G thread and NPT thread are available.

### Coil specification

Item	specification
Standard voltage	AC220V、AC110V、AC24V、DC24V、DC12V
Scope of voltage	AC: ±15% DC: ±10%
Power consumption	AC: 7VA DC: 7.0W
Protection	IP65(DIN40050)
Temperature classification	B Class
Electrical entry	Terminal, Grommet
Activating time	0.05 sec and below
Max. frequency [Note1]	10 cycle/sec

[Note1] The maximum actuation frequency is in the no-load state.

### Ordering code

#### Ordering code for valve

**3V2M NC A □**

①    ②    ③    ④

① Model	② Acting type	③ Standard voltage	④ Electrical entry
3V2M: Solenoid valve(3/2 way, with manifold)	NC: Normally closed NO: Normally opened	A: AC220V B: DC24V C: AC110V E: AC24V F: DC12V	Blank: Terminal I: Grommet

#### Ordering code for manifold

**3V2M 5F D □**

①    ②    ③    ④

① Model	② Number of stations	③ Exhaust type	④ Thread type
3V2M: Solenoid valve(3/2 way, with manifold)	1F: 1 Stations 2F: 2 Stations ..... 20F: 20 Stations	Blank: Centralized exhaust D: Separated exhaust	Blank: PT G: G T: NPT

[Note]: Manifold kits contains manifold, seal and screw.  
The port size is only 1/8".

#### Ordering code for valve's group(valve+manifold)

**3V2M NC A □ - 5F D □**

①    ②    ③    ④    ⑤    ⑥    ⑦

① Model	② Acting type	③ Standard voltage	④ Electrical entry	⑤ Number of stations	⑥ Exhaust type	⑦ Thread type
3V2M: Solenoid valve (3/2 way, with manifold)	NC: Normally closed NO: Normally opened	A: AC220V B: DC24V C: AC110V E: AC24V F: DC12V	Blank: Terminal I: Grommet	1F: 1 Station 2F: 2 Stations 3F: 3 Stations ..... 20F: 20 Stations	Blank: Centralized exhaust D: Separated exhaust	Blank: PT G: G T: NPT

#### Ordering code for blank plate

**P-3V2M-R2**

①    ②    ③

① Subassembly type	② Valve type	③ Accessories type
P: subassembly	3V2M: Solenoid valve(3/2 way, with manifold)	R2: Blank plate for manifold

[Note]: Blank plate kits contains blank plate and screw.

# Solenoid valve(3/2 way)

## 3V2M Series

### Flow chart

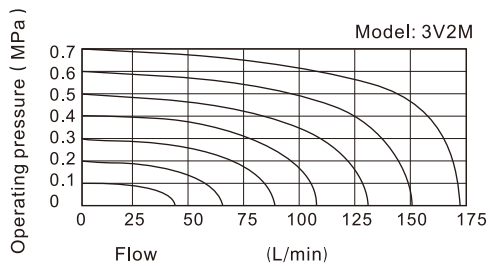

### Inner structure

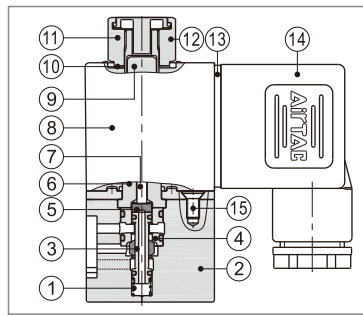

No.	Item	No.	Item
1	Spring	9	Armature
2	Body	10	Washer
3	Spool	11	Coil nut
4	Spacer	12	Manual button
5	Washer	13	Gasket
6	Electromagnet set	14	Connector
7	Man drill	15	Pilot screw
8	Coil		

### Dimensions

#### Valve(Terminal)

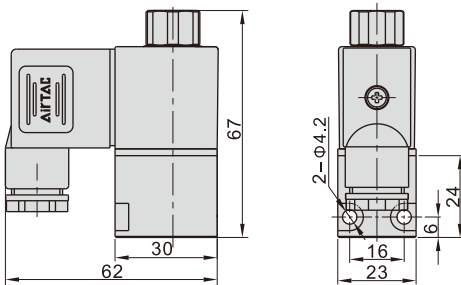

#### Valve(Grommet)

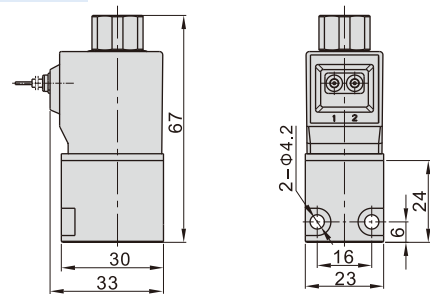

#### Valve's group(Terminal, Centralized exhaust)

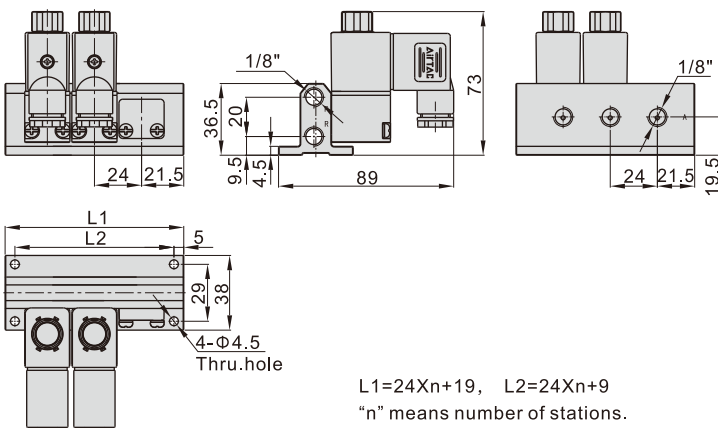

#### Valve's group(Grommet, Centralized exhaust)

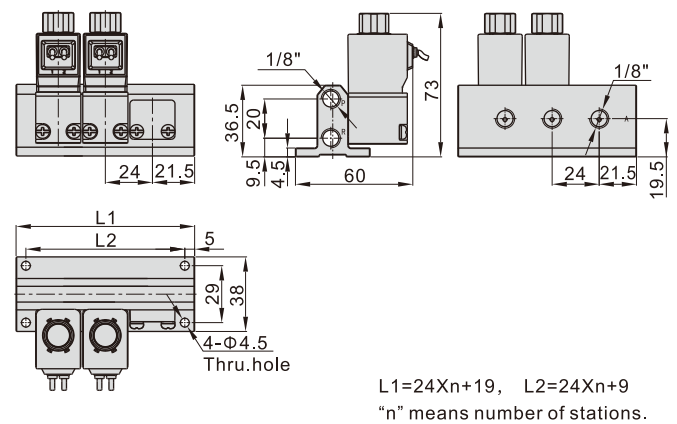

#### Valve's group(Terminal, Separated exhaust)

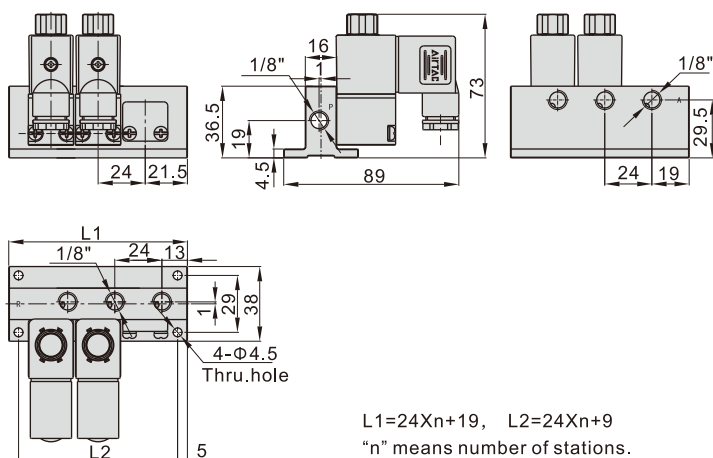

#### Valve's group(Grommet, Separated exhaust)

